

|  |  |             |                  |            |      |            |             |
|--|--|-------------|------------------|------------|------|------------|-------------|
|  <b>INFN - Sezione di PADOVA</b><br>Servizio Progettazione Officina Elettronica |  | PROJECT BY  | L. Castellani    | EXPERIMENT | QUAX | BOARD NAME | QUAX V3 CPU |
|  |  | DRAWN BY    | L. Castellani    | PAGE TITLE | CPU  | REV        | 0           |
| DESIGN SERIAL NUMBER<br><SERIAL NUMBER>  |  | DATE & TIME | 02/04/2019:12:47 | SIZE       | A3   |            |             |

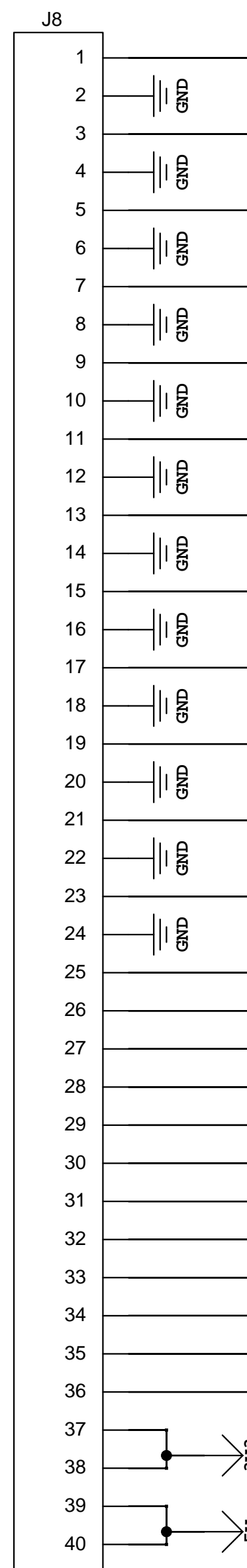

CONN\_FLAT\_VM\_40\_2.54

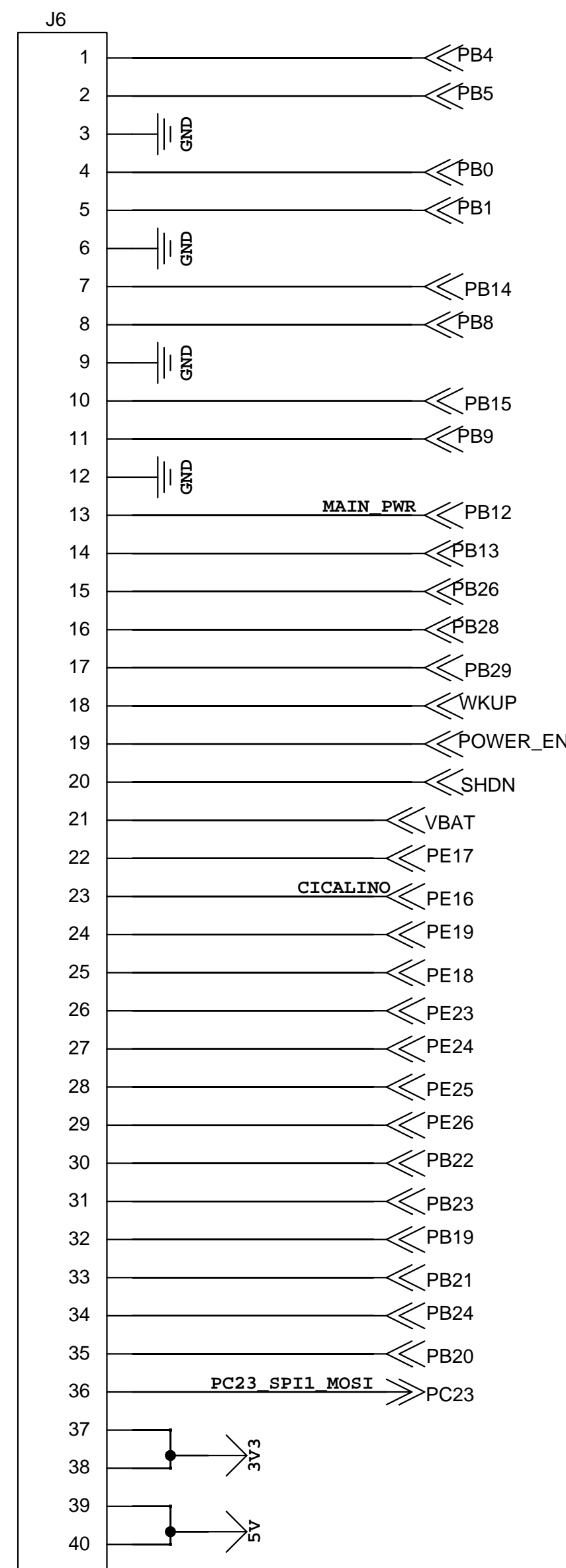

CONN\_FLAT\_VM\_40\_2.54

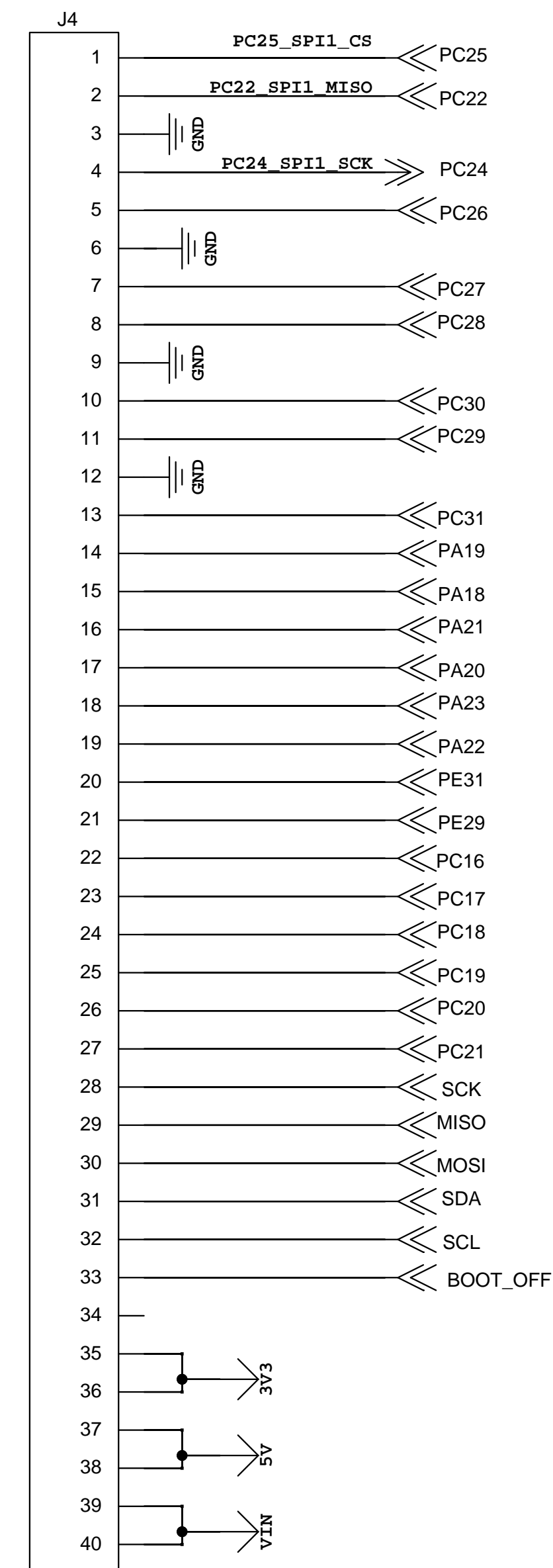

CONN\_FLAT\_VM\_40\_2.54

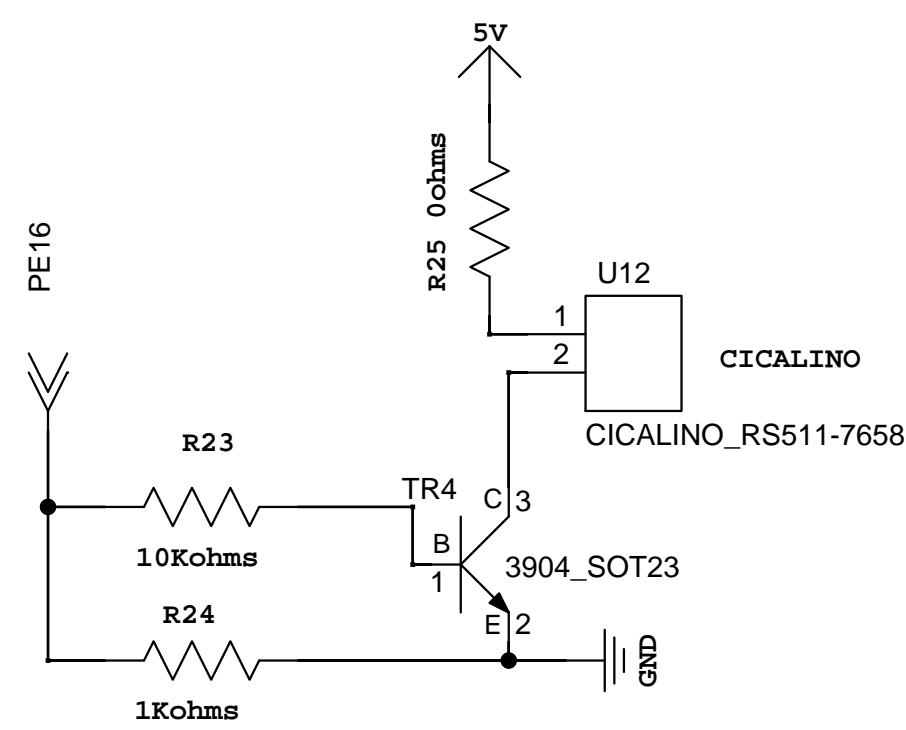

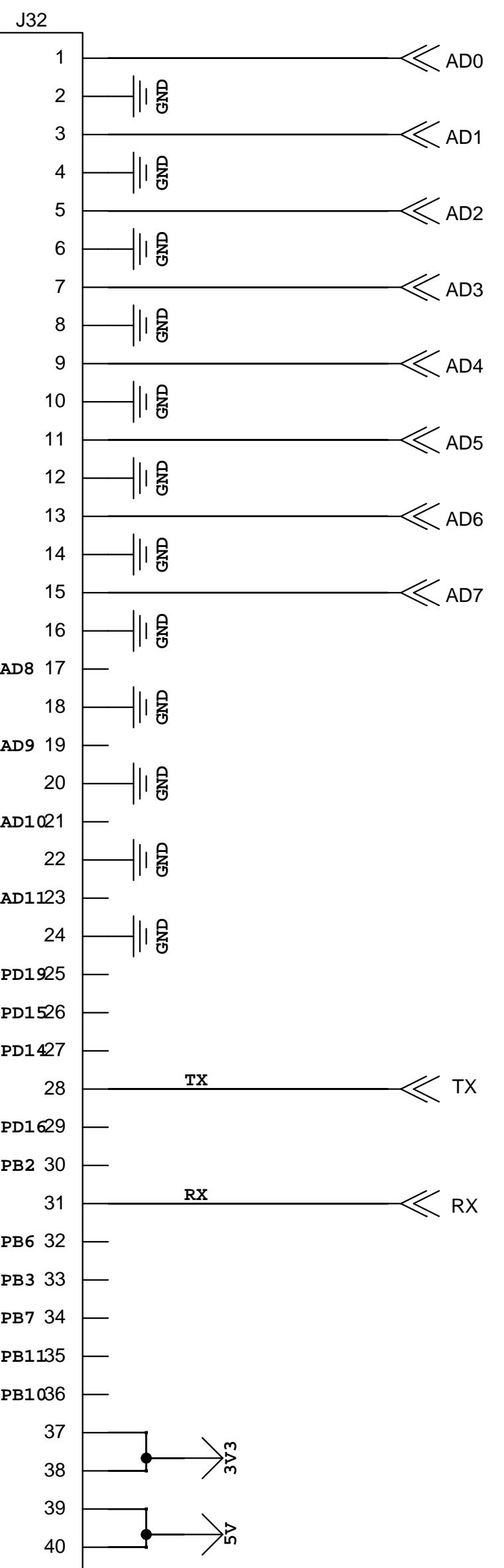
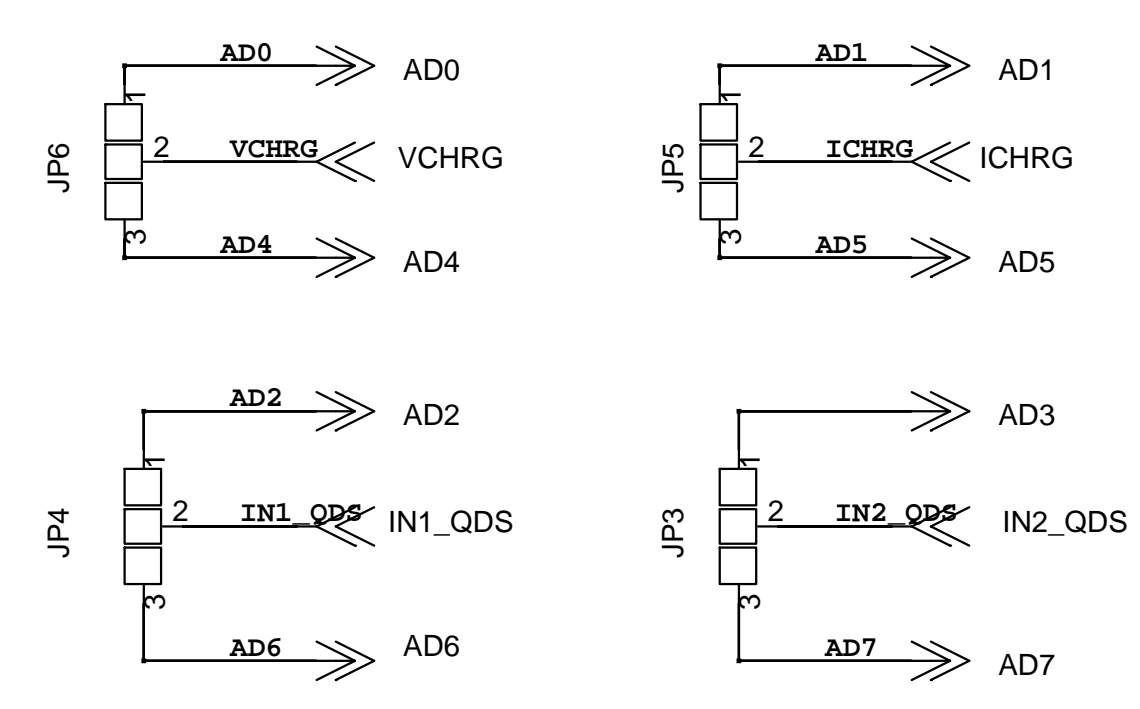

Strip2V\_40\_VF

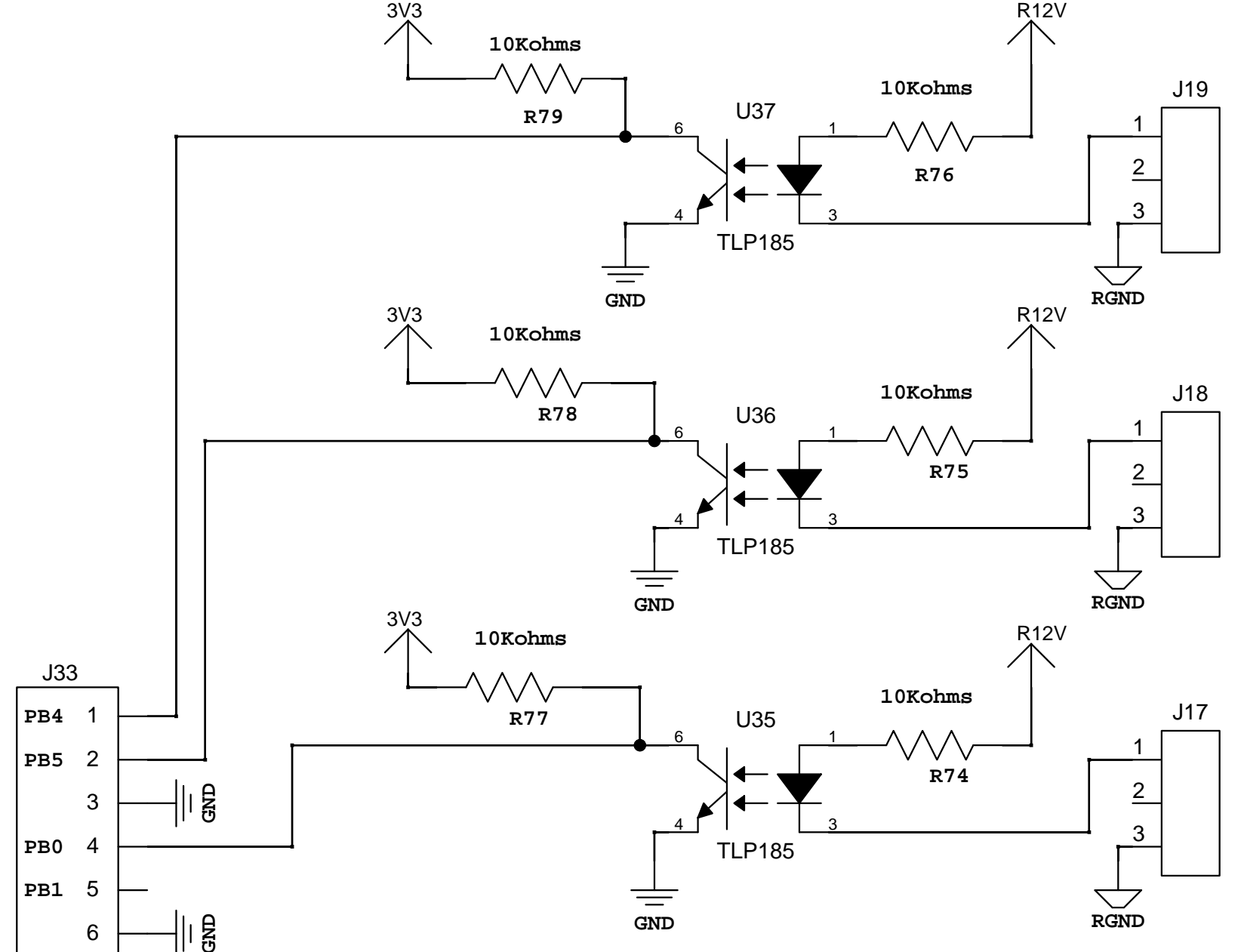

Strip2V\_40\_VF

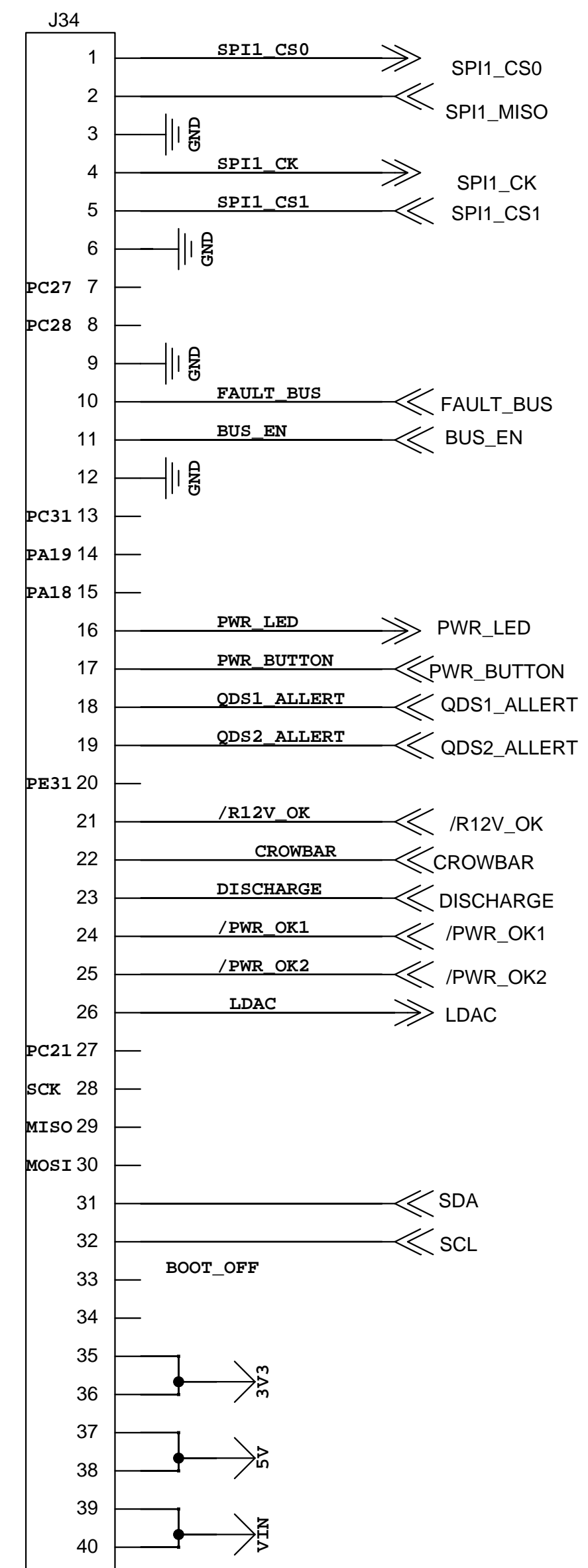

Strip2V\_40\_VF

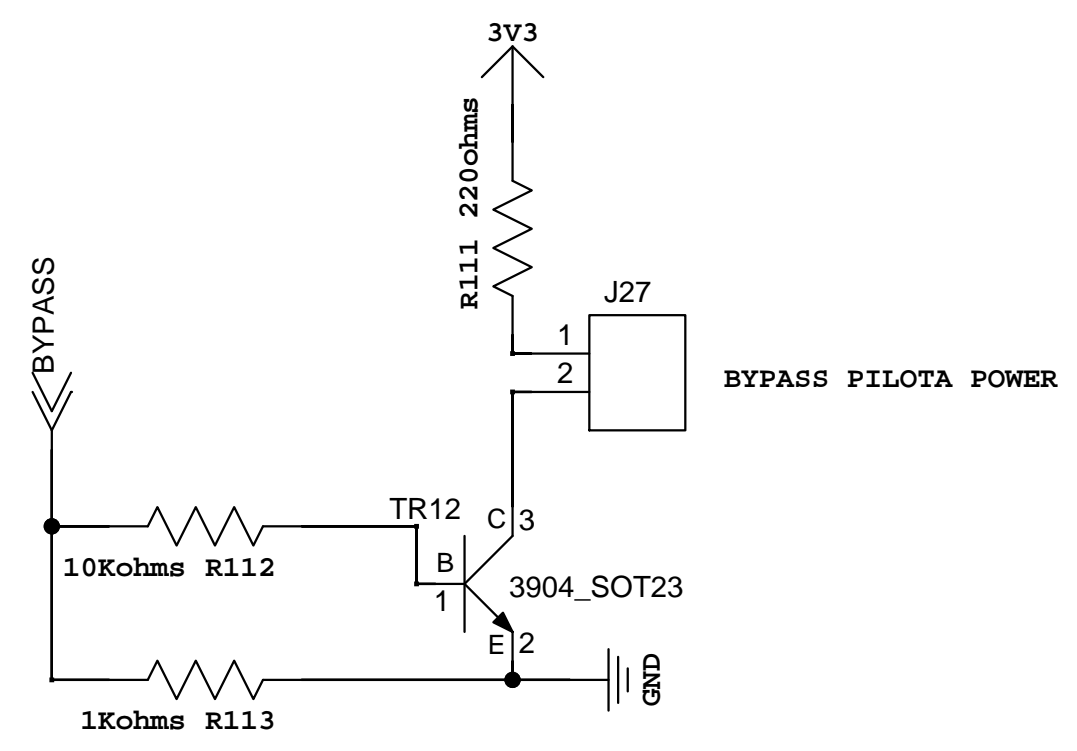

|   |  |  |                    |
|---|--|--|--------------------|
|   |  | <b>INFN - Sezione di PADOVA</b><br>Servizio Progettazione Officina Elettronica |                    |
|   |  | PROJECT BY<br>L. Castellani  | EXPERIMENT<br>QUAX |
| DRAWN BY<br>L. Castellani               |  | PAGE TITLE<br>I/O  |                    |
| DESIGN SERIAL NUMBER<br><SERIAL NUMBER> |  | REV<br>0   |                    |
| SHEET<br>1 OF 4                         |  | SIZE<br>A3   |                    |
| Date & Time<br>02/04/2019:12:58         |  |  |                    |

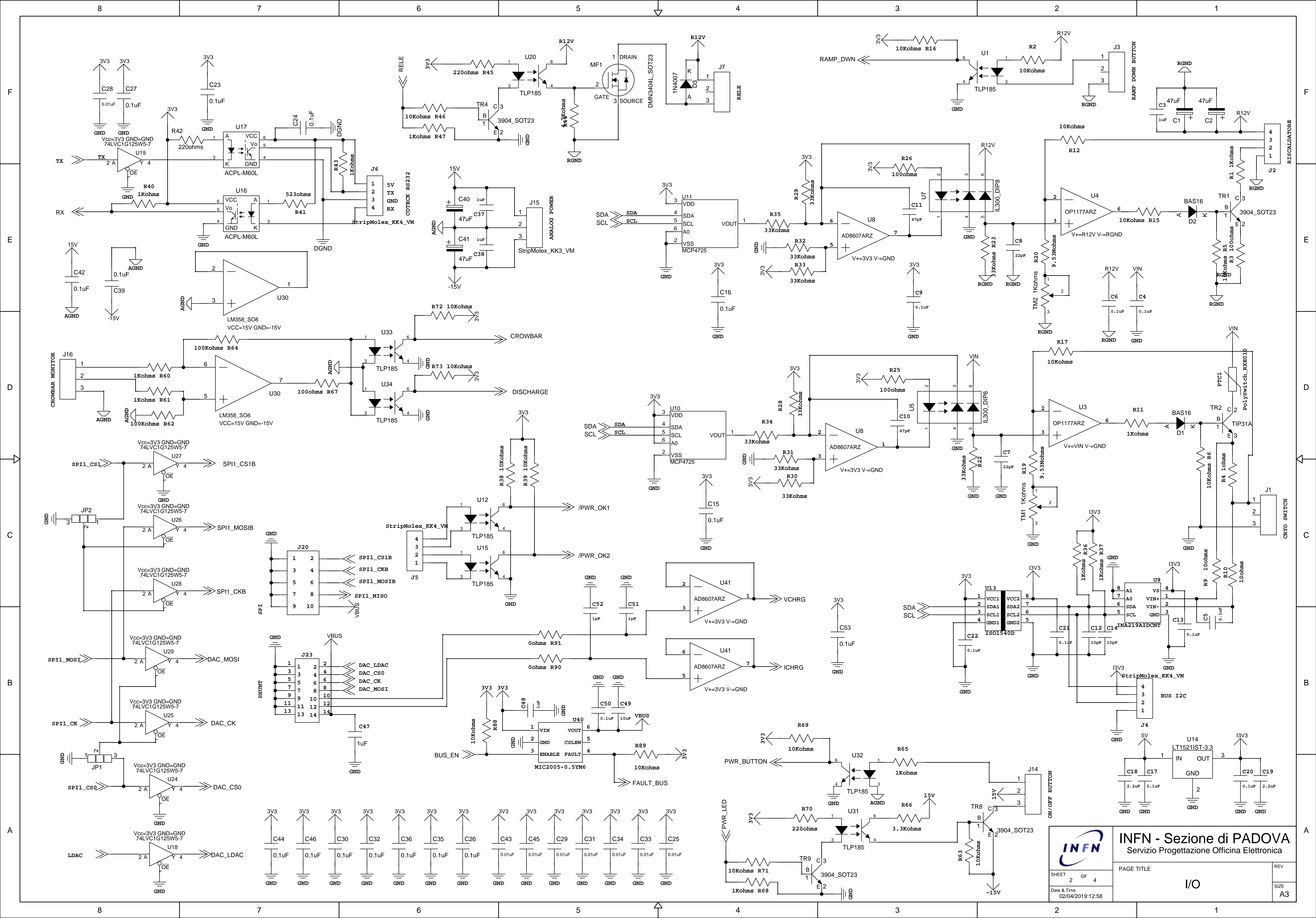

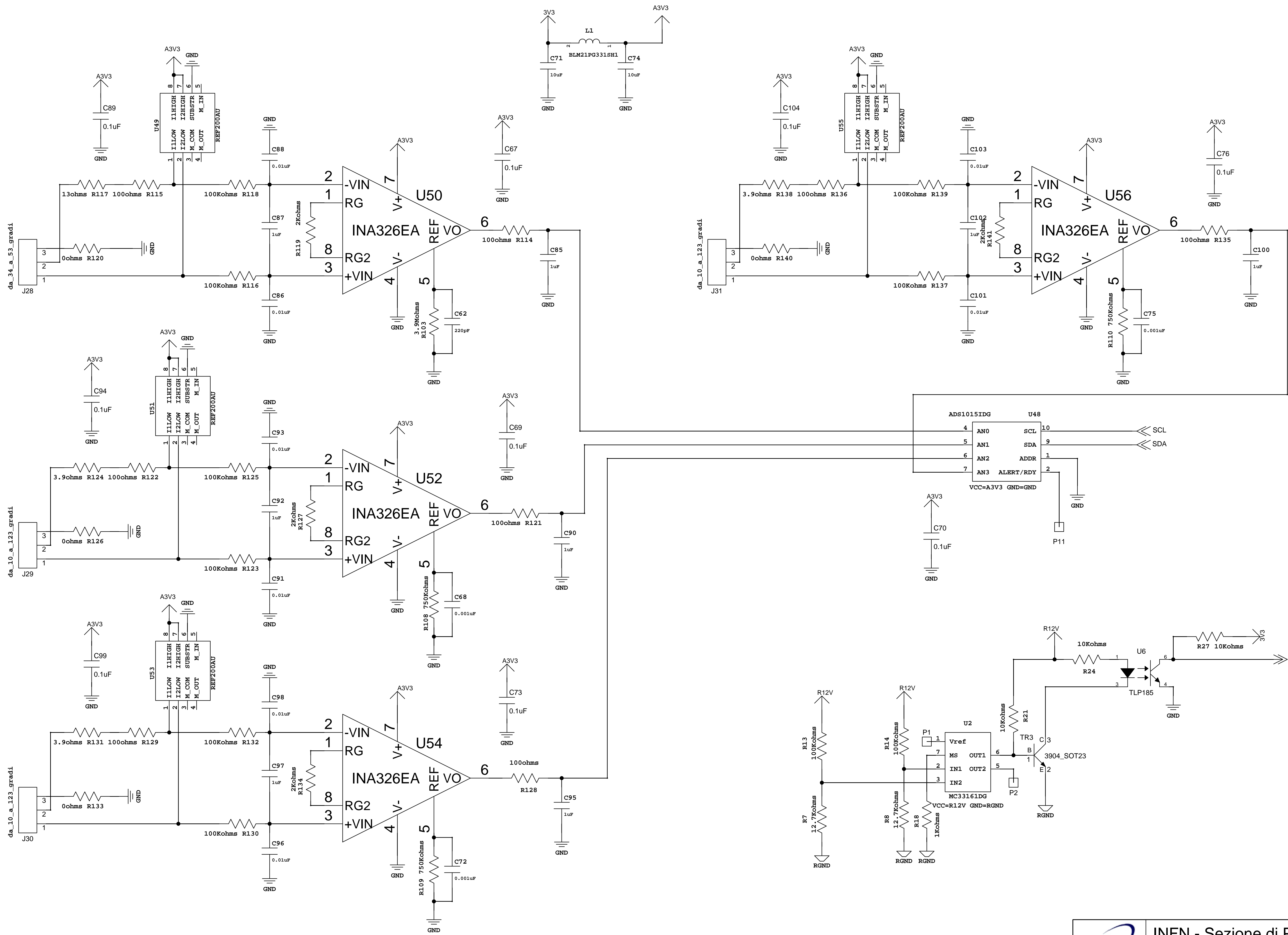

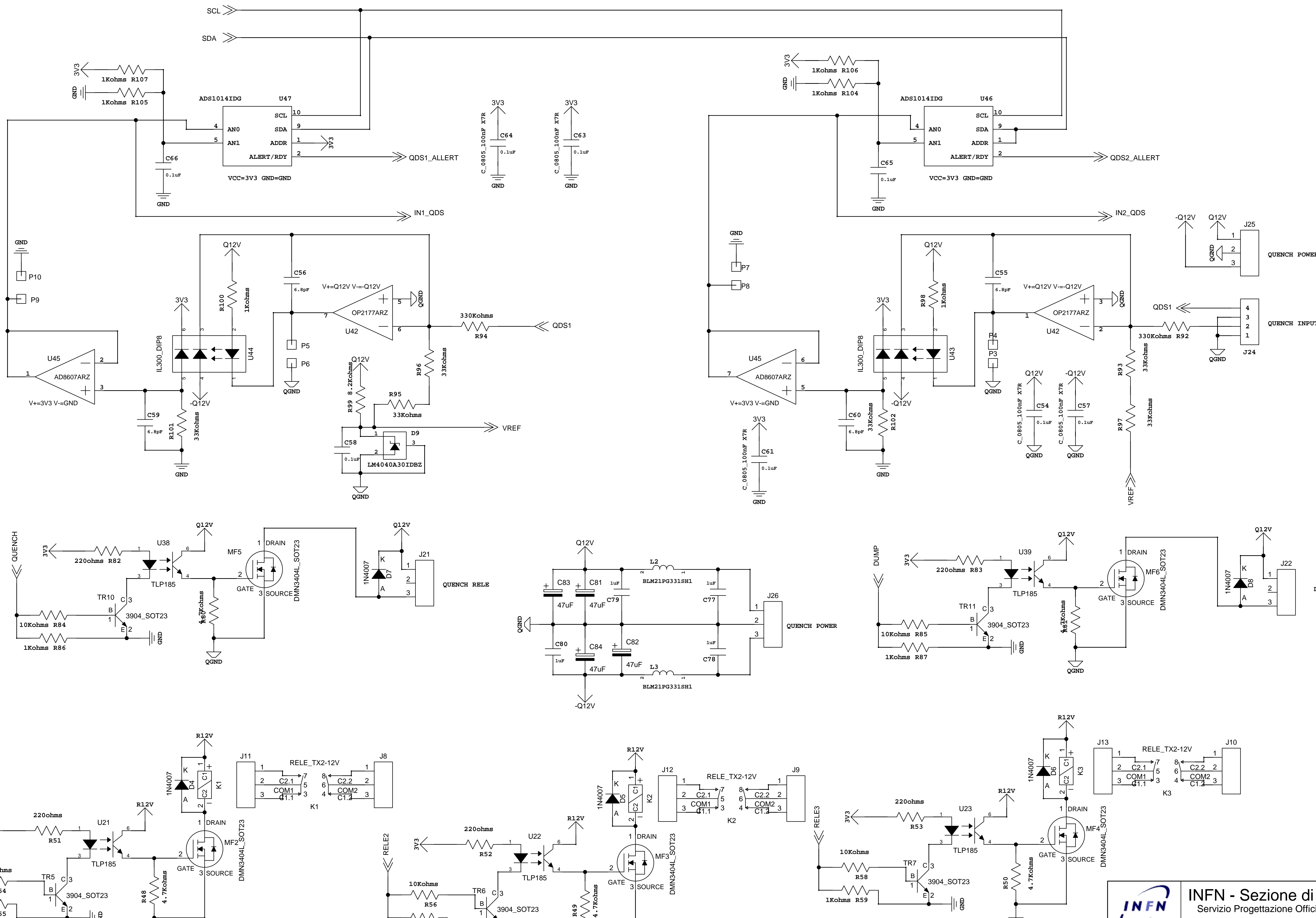

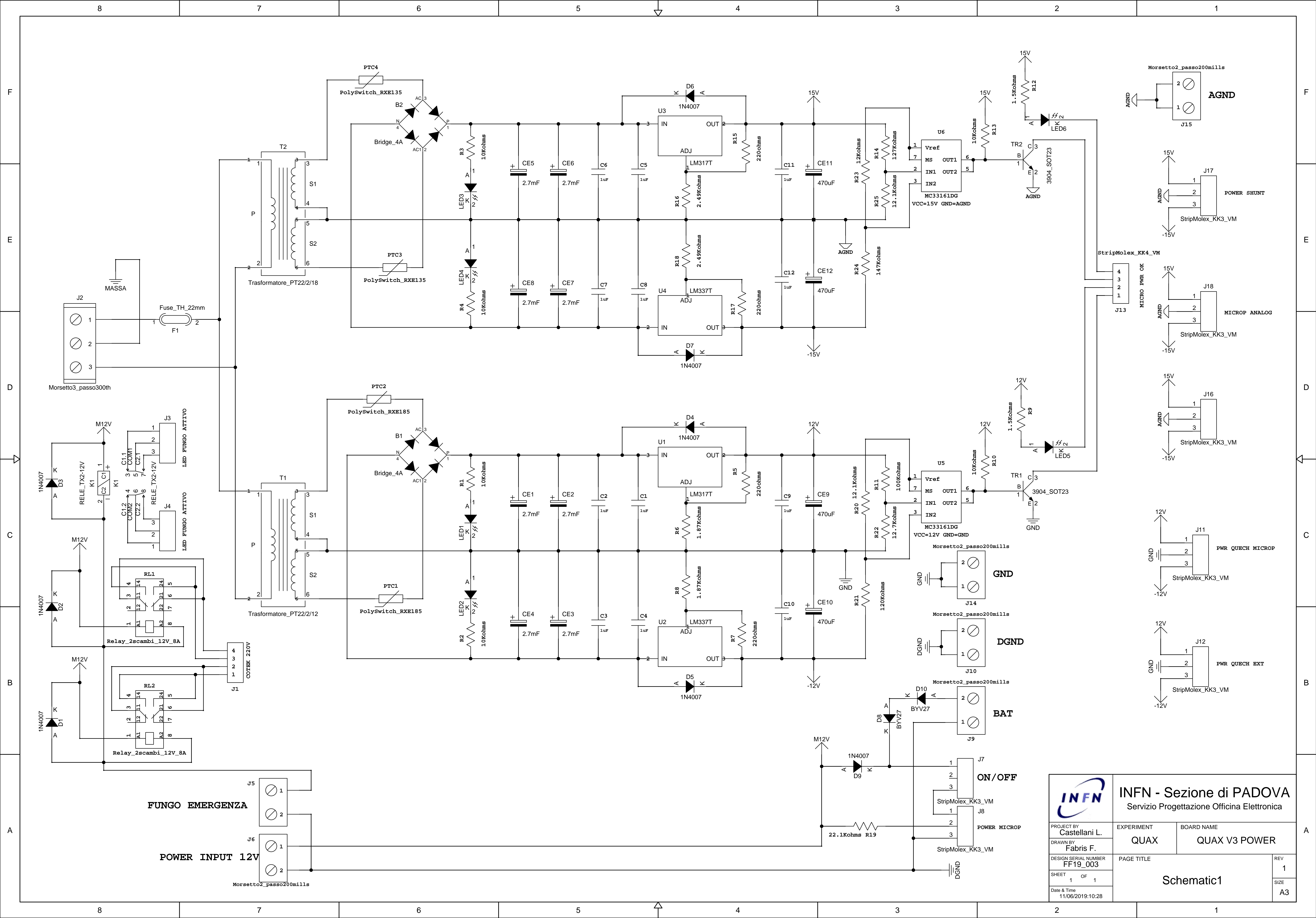

|  |  |               |               |
|--|--|---------------|---------------|
|  <b>INFN - Sezione di PADOVA</b><br>Servizio Progettazione Officina Elettronica |  | PROJECT BY    |               |
|  |  | Castellani L. |               |
| DRAWN BY   |  | EXPERIMENT    | BOARD NAME    |
| Fabris F.  |  | QUAX          | QUAX V3 POWER |
| DESIGN SERIAL NUMBER   |  | PAGE TITLE    |               |
| FF19_003   |  | Schematic1    |               |
| SHEET 1 OF 1   |  | REV 1         |               |
| Date & Time 11/06/2019:10:28   |  | SIZE A3       |               |

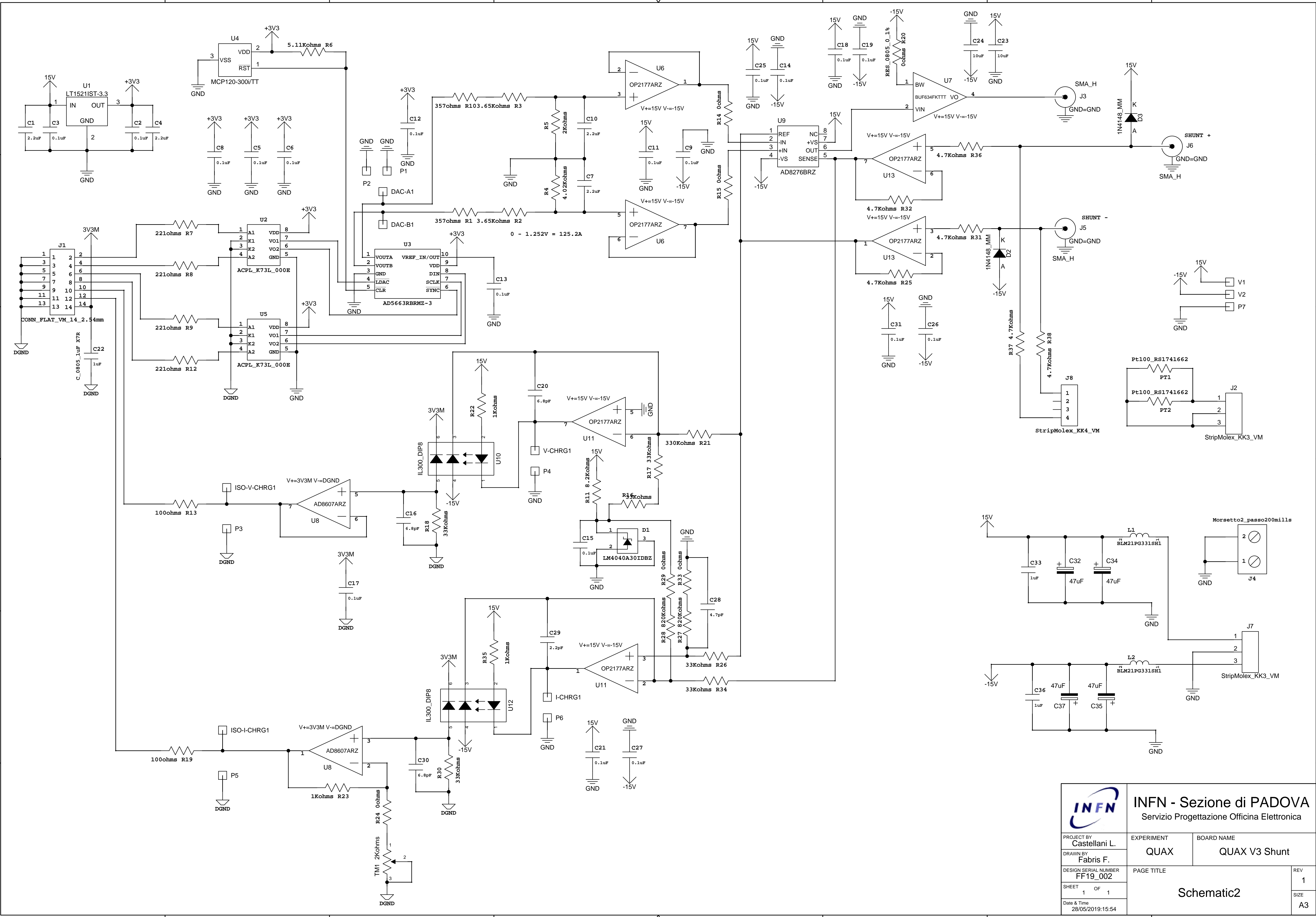

|  |  |                                    |  |             |                      |
|--|--|------------------------------------|--|-------------|----------------------|
|  <b>INFN - Sezione di PADOVA</b><br>Servizio Progettazione Officina Elettronica |  | PROJECT BY<br><b>Castellani L.</b> |  | EXPERIMENT  | BOARD NAME           |
|  |  | DRAWN BY<br><b>Fabris F.</b>       |  | <b>QUAX</b> | <b>QUAX V3 Shunt</b> |
| DESIGN SERIAL NUMBER<br><b>FF19_002</b>  |  | PAGE TITLE                         |  | REV         |                      |
| SHEET<br>1 OF 1  |  | <b>Schematic2</b>                  |  | 1           |                      |
| Date & Time<br>28/05/2019:15:54  |  |                                    |  | A3          |                      |



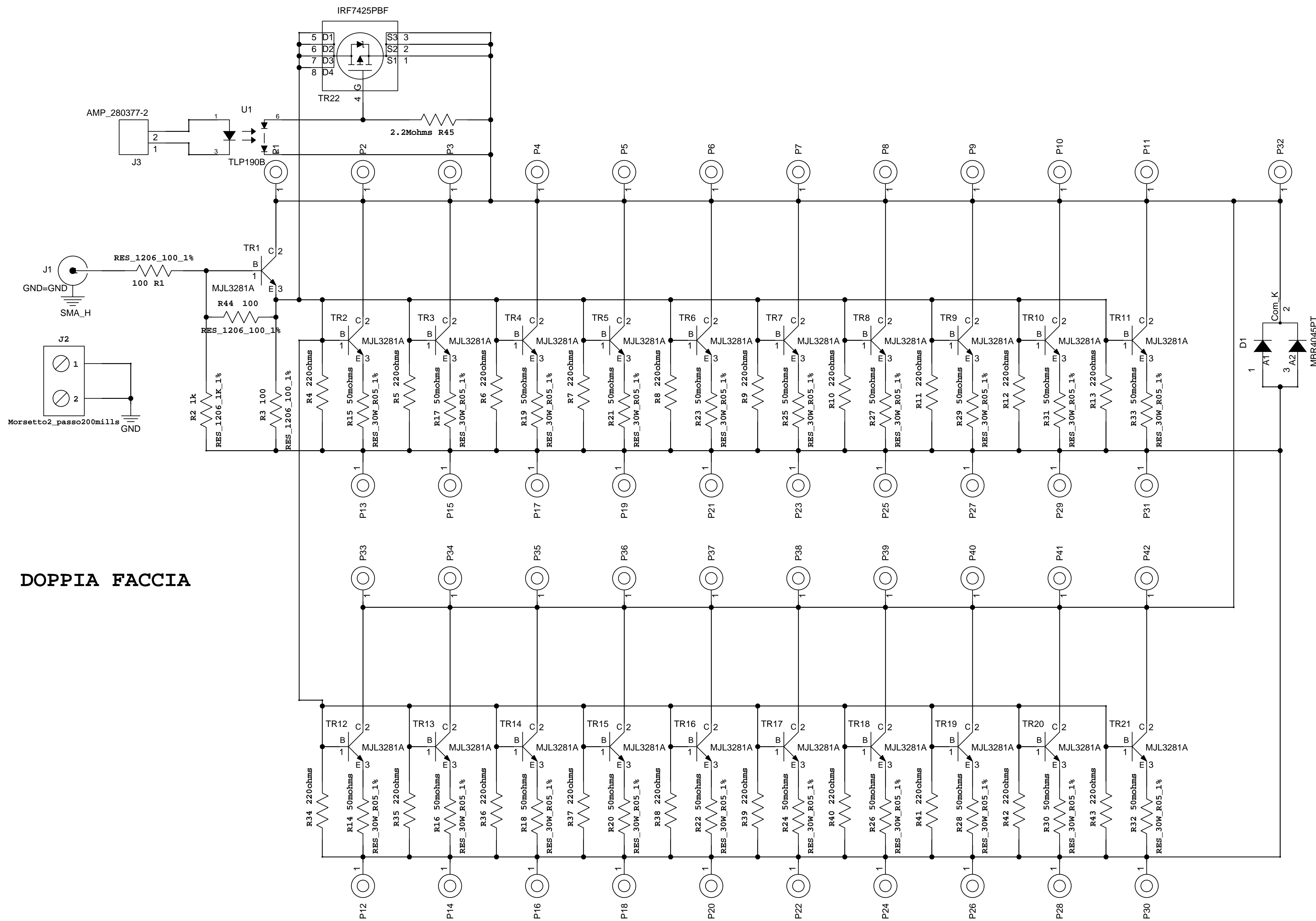

DOPPIA FACCIA

|  |  |                              |  |            |                    |
|--|--|------------------------------|--|------------|--------------------|
|  <b>INFN - Sezione di PADOVA</b><br>Servizio Progettazione Officina Elettronica |  | PROJECT BY<br><PROJECT BY>   |  | EXPERIMENT | BOARD NAME         |
|  |  | DRAWN BY<br><YOUR NAME HERE> |  | QUAX       | QUAX V3 PWR DRIVER |
| DESIGN SERIAL NUMBER<br><SERIAL NUMBER>  |  | PAGE TITLE                   |  |            | REV                |
| SHEET<br>1 OF 1  |  | Schematic2                   |  |            | 0                  |
| Date & Time<br>17/05/2019:10:11  |  |                              |  |            | SIZE<br>A3         |